

# HCR120C

HCR120C is the smallest diesel engine driven demolition robot, and its compact design and maneuverability make it suitable for many projects. It can be accessed through ordinary porches and narrow passages, with maneuverability and flexibility, without dragging cables, and has great load-bearing capacity and strong obstacle crossing ability. It can climb stairs or 30° slopes.

## Widely used in:

- Metallurgical furnace maintenance and slag removal
- Emergency rescue
- Nuclear accident rescue and nuclear waste treatment
- Demolition and renovation of commercial and industrial buildings



## TECHNICAL DATA

Slewing speed	10 s/360°
Transport speed	2.2/4.0 km/h(Slow/Fast)
Incline angle, max.	30°
Hydraulic system capacity	40 L
Pump type	Variable load-sensing
System pressure	19 MPa
Pump flow	0-50 L/min
Engine	Inline 3-cylinder water-cooled four stroke diesel engine
Output	18.7 kW
Fuse	5A/10A/15A According to different routes
Starting device	Direct start
Control type	Portable control box
Signal code	Digital
Transfer	Professional radio/Cable
Range, radio	100 m
Weight of machine excluding attachment	1500 kg
Recommended attachment weight	160 kg

## OPTION

Working attachments such as buckets and hydraulic shears
Rubber track/steel track
Mechanical quick coupling
Forced air cooling
Oil cylinder special protection
Hydraulic hammer water jet function
Backup oil circuit (extra hydraulic function)
Track steel pads/other chisels
High temperature hose/nuclear protection
Hydraulic oil circuit automatic conduction quick coupling/hydraulic wrist
Remote video system, sensors
Fire cannon, booster and bulldozer

## SIZE

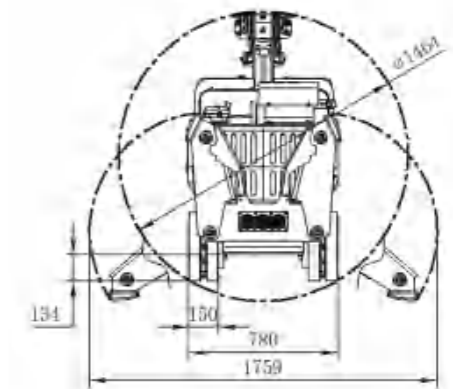
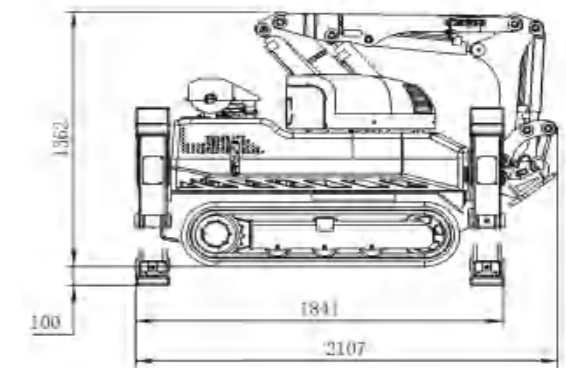

## RANGE

