

RXR-M200D-AHHC Firefighting Robot

It is diesel engine and equipped with an ATV hydraulic tracked chassis, which makes it maneuverable and flexible. It can turn in place, climb slopes, and has strong off-road capabilities. The imported fire cannon with a large flow rate of 150L/s it is equipped with has a long firing range and can effectively meet the needs of fighting large-scale fires. The fire-fighting robot can effectively replace trailer guns and mobile guns. It can remotely control the fire cannon to the required position using its own power, and effectively substitute firefighters to approach the fire source and dangerous areas for reconnaissance, fire fighting and other operations. Operators can carry out fire-fighting operations at a distance outside the fire source, avoiding unnecessary casualties.

Widely applied in:

- Reconnaissance and data collection of dangerous fire targets, reconnaissance, attack and cover of targets, etc.
- Firefighting in situations where large fire trucks and personnel are difficult to approach and rescue and disaster relief in dangerous situations
- For highway (railway) tunnels, subway stations, underground facilities and freight yards
- Fires in large-span and large-space places, petrochemical oil depots and refineries
- Large-scale toxic gas and smoke accidents and dangerous fires
- Fires in industrial plants and civil buildings



PARAMETER

Machine weight	1900kg
Overall dimensions(L*W*H)	2310*1460*1860mm
Driving speed	0-7.2km/h
Diesel fuel tank capacity	60L
Hydraulic oil tank capacity	80L
Rated working pressure	1MPa
Climbing ability	40°
Side tilt stability angle	30°
Ground clearance	200mm
Obstacle crossing height	200mm
Video transmission distance	1000m
Engine power	46.3kW
Traction force	15kN

SYSTEM PARAMETER

Range of the water cannon	110m
Max. flow rate of the water cannon	150L/s
Pitch angle	-30°~90°
Slewing angle of the water cannon	±120°

STRONG POWER

Powered by an imported engine; All-terrain tracked drive. It can connect four high-pressure water hoses and drag them to the designated position.

SELF PROTECTION FUNCTION

The robot body is equipped with a fully enclosed automatic water mist spraying protection system. The spraying nozzles form a water mist protection circle, which can effectively prevent the thermal radiation from the surrounding environment from entering and cool down the robot at the same time. It will be automatically turned on during fire fighting operations.

EASY TO OPERATE

The lightweight wireless remote control has a remote control distance of up to 1000 meters and can remotely control all actions of the machine.

SIZE

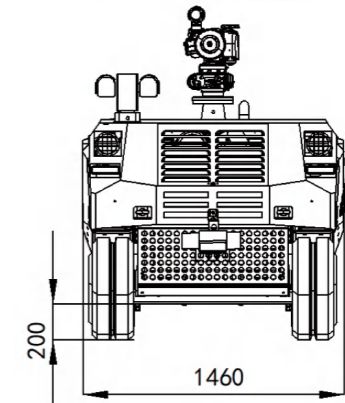
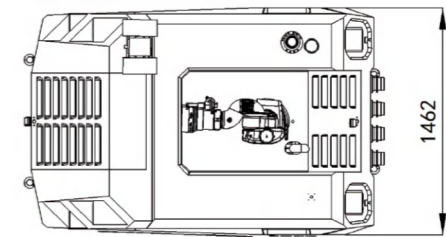
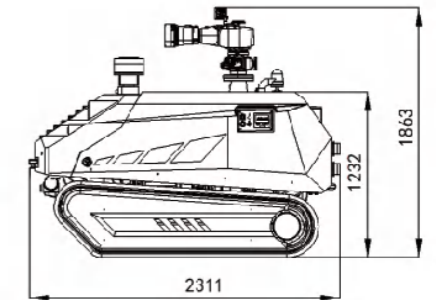

SMOOTH DRIVING

It adopts stepless speed change with two gears of fast and slow, enabling it to travel quickly and also climb slopes and cross obstacles at a low speed.

STRONG THROUGH ABILITY

It adopts a hydraulic tracked walking chassis, which is maneuverable and flexible. It can turn in place, has strong climbing ability, can cross obstacles, has strong off-road capabilities, and is adaptable to complex terrains.

SMOOTH BRAKING

The automatic hydraulic braking device provides stable braking and reliable parking on slopes.